

THIS DRAWING IS UNPUBLISHED. RELEASED FOR PUBLICATION
 © COPYRIGHT BY TYCO ELECTRONICS CORPORATION. ALL RIGHTS RESERVED.

LOC	DIST	REVISIONS					
DF	DO	P	LTR	DESCRIPTION	DATE	DWN	APVD
		J		REV PER 0H14-0287-05	26OCT05	PY	DM

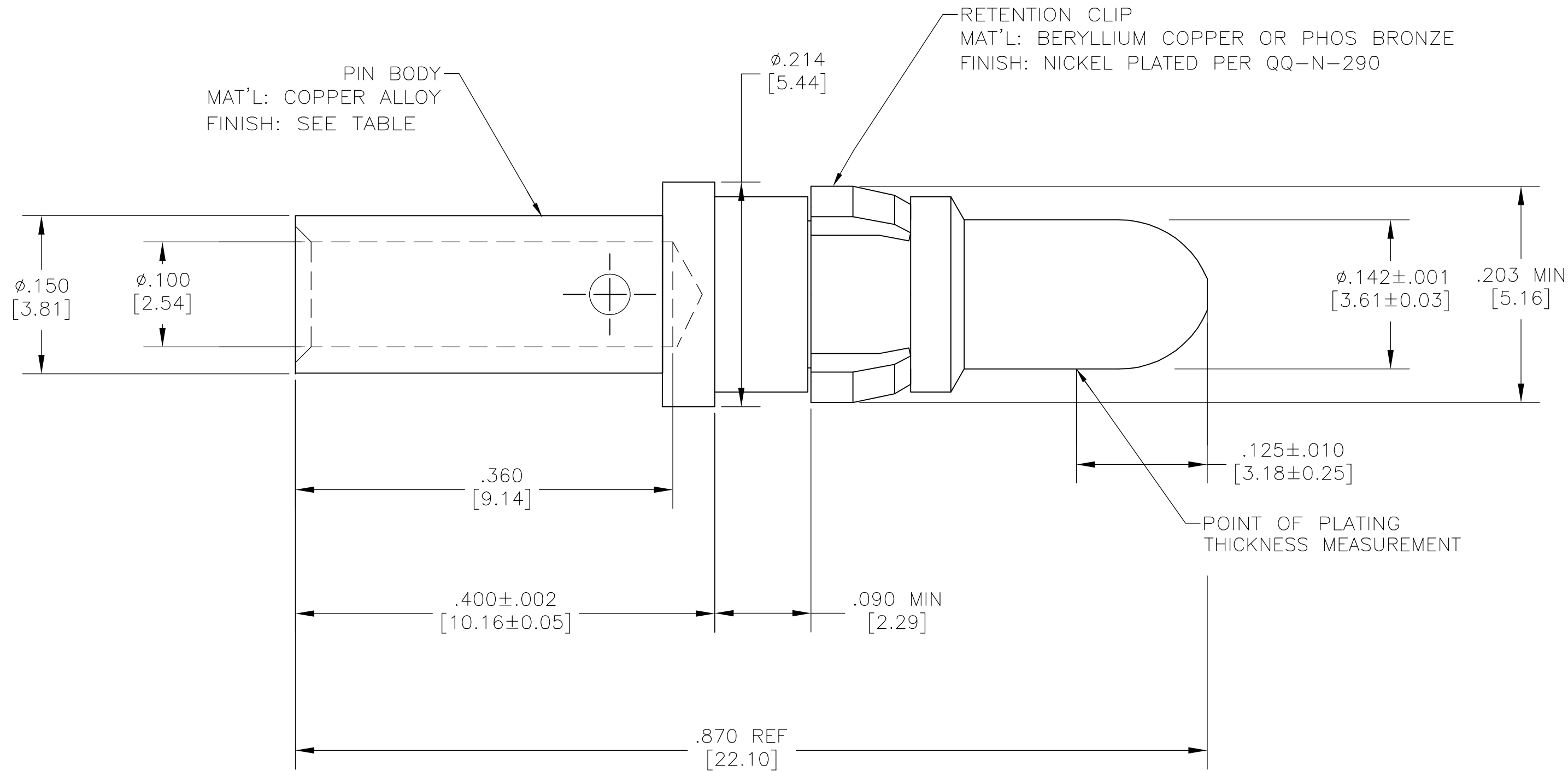

- THIS PART CONFORMS TO REQUIREMENTS FOR DANIELS CRIMP TOOL NO. M300-BT, WITH DANIELS POSITIONER PART NO. SP689, STRIP LENGTH .375, SETTING #1.
- MATES WITH 212008-1 IN AMPLITE CONNECTOR ASSEMBLIES ONLY.
- FINISH: PLATED GOLD .000050 [0.00127] MIN THK PER MIL-G-45204 OVER NICKEL .000050 [0.00127] MIN THK PER QQ-N-290.
- FINISH: PLATED GOLD .000030 [0.00076] MIN THK PER MIL-G-45204 OVER NICKEL .000050 [0.00127] MIN THK PER QQ-N-290.
- WIRE BARREL WILL ACCEPT #12-#14 AWG WIRE.

4	212007-2
3	212007-1
FINISH	PART NUMBER

THIS DRAWING IS A CONTROLLED DOCUMENT.		DWN	C.C.THOMAS	11/10/00	 Tyco Electronics Corporation Harrisburg, Pa 17105-3608														
DIMENSIONS: INCHES		CHK	D.MILLER	11/10/00															
TOLERANCES UNLESS OTHERWISE SPECIFIED:		APVD	D.MILLER	11/10/00															
<table border="1"> <tr><td>0 PLC</td><td>± -</td></tr> <tr><td>1 PLC</td><td>± -</td></tr> <tr><td>2 PLC</td><td>± -</td></tr> <tr><td>3 PLC</td><td>± .005 [0.13]</td></tr> <tr><td>4 PLC</td><td>± -</td></tr> <tr><td>ANGLES</td><td>± -</td></tr> <tr><td>FINISH</td><td>SEE TABLE</td></tr> </table>		0 PLC	± -	1 PLC		± -	2 PLC	± -	3 PLC	± .005 [0.13]	4 PLC	± -	ANGLES	± -	FINISH	SEE TABLE	PRODUCT SPEC	108-10045	NAME
0 PLC	± -																		
1 PLC	± -																		
2 PLC	± -																		
3 PLC	± .005 [0.13]																		
4 PLC	± -																		
ANGLES	± -																		
FINISH	SEE TABLE																		
MATERIAL	SEE CALLOUTS	APPLICATION SPEC	114-10014	SIZE	A2														
		WEIGHT	-	CAGE CODE	00779														
		CUSTOMER DRAWING		DRAWING NO	C=212007														
		SCALE	10:1	SHEET	1 OF 1														
		REV	J																